

322

MODELLI MODELS	MOMENTO LIFTING MOMENT	SBRACCIO ORIZ. HORZ. HYDRAULIC OUTREACH	PORTATA AL DISTRIBUTORE OIL FLOW TO THE CONTROL VALVE	SBRACCIO MAX. VERTICALE MAX VERTICAL REACH	PESO WEIGHT	PRESSIONE PRESSURE	INTERASSE STABILIZZATORI STANDARD APERTI DISTANCE BETWEEN CENTRES WITH OPENED OUTRIGGERS
	Tm.	m.	l/min	m.	Kg	bar	mm.
322A1	2.00	2.17	8	3.57	192	160	3140
322A2	2.00	3.18	8	4.51	219	160	3140

Autocarro consigliato - Recommended truck - Camion conseillé - Camion aconsejado
M.T.T. ton 2 - G.V.W. ton 2

STANDARD



Angolo di rotazione
Slewing angle



Serbatoio olio
Oil Tank

STANDARD CE



Limitatore di momento
Overload device

322 A1

m	1.25	2.17	3.18	4.14
Kg	1590	920	625	400

322 A2

m	1.33	2.25	3.18	4.14
Kg	1485	870	615	400

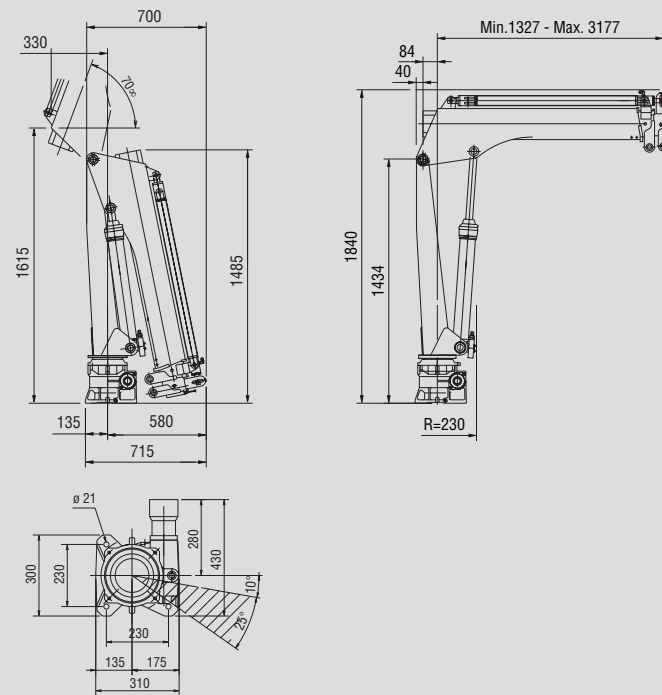

SPAZIO RICHIESTO PER L'INSTALLAZIONE NECESSARY SPACE FOR INSTALLATION

322	STD	con attivazioni
322A1	460	460
322A2	460	460

F.lli FERRARI CORPORATION S.p.A.

Via Pasubio, 3

42022 Boretto (RE) Italy

Tel. +39 0522/ 964921

Fax +39 0522/964405

E-mail:marketing@flliferrari.it

M.K.T.5800118 05/04 3000

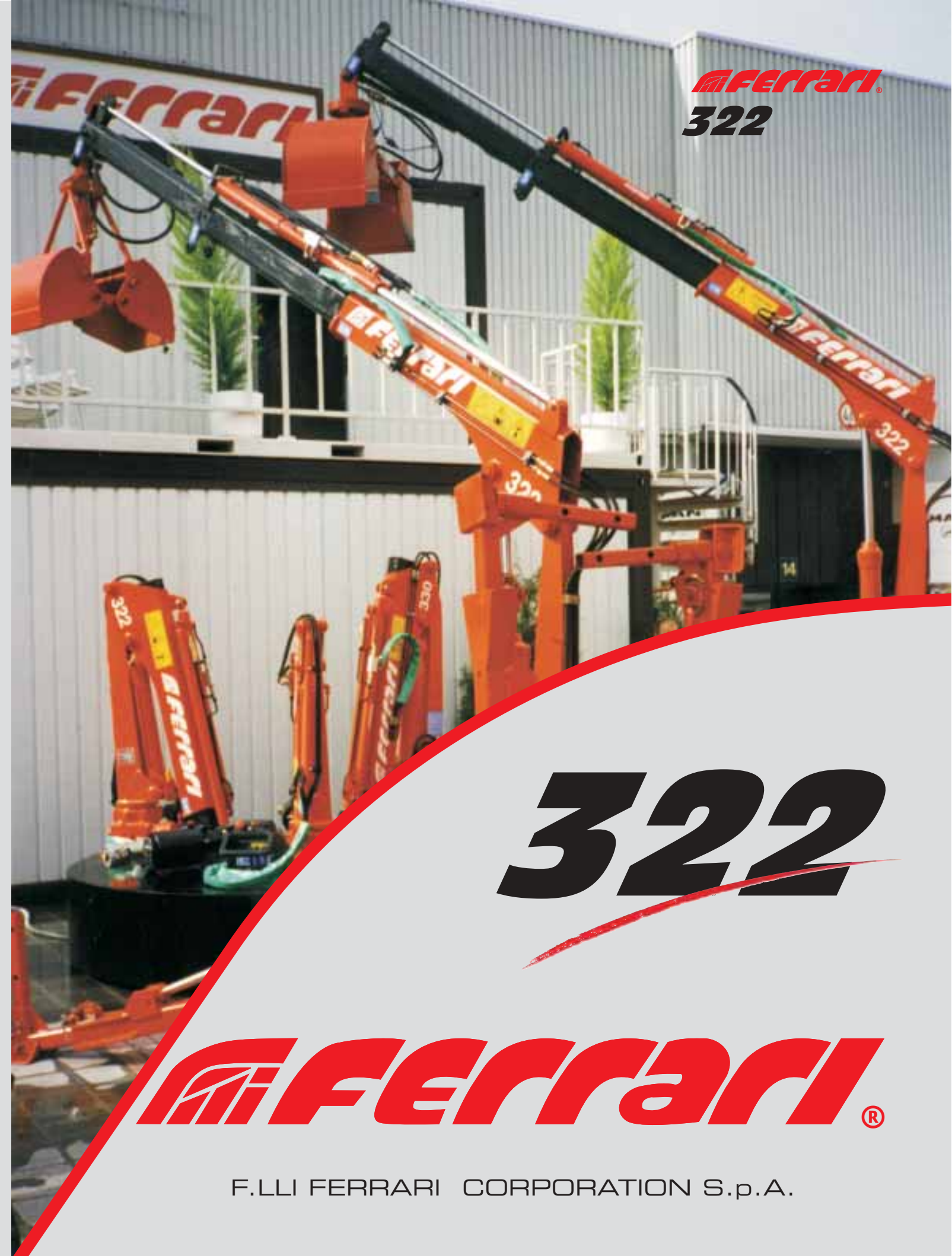

322

F.LLI FERRARI CORPORATION S.p.A.

Dati, descrizioni e illustrazioni sono indicativi e non impegnano F.lli Ferrari. Gru prodotte e/o commercializzate da F.lli Ferrari - Data, descriptions and illustrations are merely indicative and not binding. Cranes manufactured and marketed by F.lli Ferrari - Les données, descriptions et illustrations sont uniquement indicatives et n'engagent pas F.lli Ferrari. Grues produites et/ou vendues par F.lli Ferrari - Angaben, Beschreibungen und Abbildungen sind weisend und verpflichten nicht F.lli Ferrari. Die Kräne werden von F.lli Ferrari hergestellt und/oder vermarktet - Los datos, las descripciones y las ilustraciones son indicativos y no implican compromiso para F.lli Ferrari. Gruas producidas y/o comercializadas por F.lli Ferrari - Os dados as descrições e ilustrações são indicativos e não comprometem F.lli Ferrari. Guindaste produzidos e/ou comercializados pela F.lli Ferrari.

FERRARI 322



①

La gru F.Ili Ferrari mod. 322 racchiude in se caratteristiche tecniche e meccaniche di elevata qualità

- Acciai ad alto limite di snervamento
- Basamento e pignone colonna in fusione
- Struttura interamente sabbiata
- Bracci esagonali
- Sbracci fino a 3.18 m (4.14 con prolunga meccanica)
- Valvole di sicurezza flangiate
- Pannello comandi posizionabile a piacere
- Carter di protezione comandi in ABS
- Sistema di rotazione con vite senza fine
- Mart. sfilo indipendenti
- Pattini di scorrimento con ripresa gioco autoserrante
- Boccole autolubrificanti
- Raccordo SAE J 1514I
- Gancio girevole
- Kit di montaggio compreso

Accessori

- Attivazione elementi supplementari*
- Stabilizzatori allargabili manualmente
- Serbatoio olio
- Prolunghe meccaniche
- Stabilizzatori girevoli
- Centralina elettroidraulica

*) 1S-2S



GB

The crane model 322 from F.Ili Ferrari has been projected and manufactured with high quality technical and mechanical characteristics

- Steel at high yielding edge
- Basement and column pinion by melding made
- Structure fully sandblasted
- Hexagonal booms
- Hydraulic outreach until 3.18 mt (4.14 with mechanical boom)
- Flanged valves
- Control panel with customised position
- Controls guard pan by ABS
- Worm screw slewing
- Independent telescopic cylinders
- Sliding pad with self-adjusting gap
- Self-tapping bushings
- SAE JIC 1514I fittings
- Turning hook
- Mounting kit included

Accessories

- Extra elements activation*
- Manually opening outriggers
- Oil Tank
- Mechanical booms
- Turning outriggers
- Electro-hydraulic gearbox



F

LA grue modèle 322 F.Ili Ferrari est conçue avec des caractéristiques techniques et mécaniques de plus haute qualité

- Acier à haut niveau de déformation plastique
- Embase et pignon colonne moulés
- Structure complètement sablée
- Rallonges hexagonales
- Portée Hydraulique jusqu'à 3.18 Mt (4.14 mt avec rallonges mécaniques)
- Vannes bridées
- Panneau de commandes à positionner selon la demande
- Enveloppe de protection commande en ABS
- Rotation par vis sans fin
- Vérins hydrauliques indépendants
- Patins de coulissement auto enregistrables
- Douilles autolubrifiantes
- Raccords SAE-JIC 1514I
- Crochet tournant
- Kit de montage inclus

Accessoires

- Activation circuits supplémentaires*
- Béquilles à ouverture manuelle
- Réservoir huile
- Rallonges mécaniques
- Béquilles pivotantes
- Distributeur électro-hydraulique



D

Das Kranmodell 322 vom F.Ili Ferrari ist mit höchsten Qualität für technischen und mechanischen Eigenschaften projiziert und hergestellt worden

- Stahl am hohen einträglichen Rand
- Sockel und Zahnrad beim Schmelzen gemacht
- Struktur voll Sand gestrahlt
- Sechseckige Ausschube
- Hydraulischen Reichweiten bis 3.18 mt. (4.14 mt mit mechanischen Ausschube)
- Geflanscht Ventilen
- Geflanscht Ventilen
- Bedienungslage nach Wunsch
- Bedienungsschutz bei ABS
- Drehung bei Schnecke
- Unabhängige hydraulischen Hebers
- Gleitschuh mit Selbstnachsteller Spiel
- Selbstschmierende Buchsen
- SAE-JIC 1514I Anschlusse
- Schwenkbar Haken
- Einsatzbau eingeschlossen

Zubehöre

- Betätigung der Zusatzfunktionen*
- Handöffnung der Abstützungen
- Öltank
- Mechanische Ausschube
- Drehbar Abstützungen
- Elektro-hydraulisch Schaltgerät



SP

El modelo de la grúa 322 de F.Ili Ferrari se ha proyectado y fabricado con características técnicas y mecánicas de alta calidad

- Acero en el alto borde de rendimiento
- Piñón de la columna y basamento moldeados
- Estructura completamente arenada
- Prolongas hexagonales
- Alcances hidraulicos hasta mt. 3.18 (4.14 mt con prolongas mecanicas)
- Valvulas rebordeadas
- Cuadro de mando desplazable
- Carter de proteccion en ABS
- Rotacion con tornillo sin fin
- Prolongas independientes
- Patin de deslizamiento con juego autoregurable
- Casquillos autolubrificantes
- Empalmes SAE-JIC 1514I
- Gancho giratorio
- Kit de montaje incluido

Acesorios

- Elementos adicionales*
- Patas abiertura manua
- Tanque aceite
- Prolongas mecanicas
- Patas giratorias
- Central electro-hidraulica

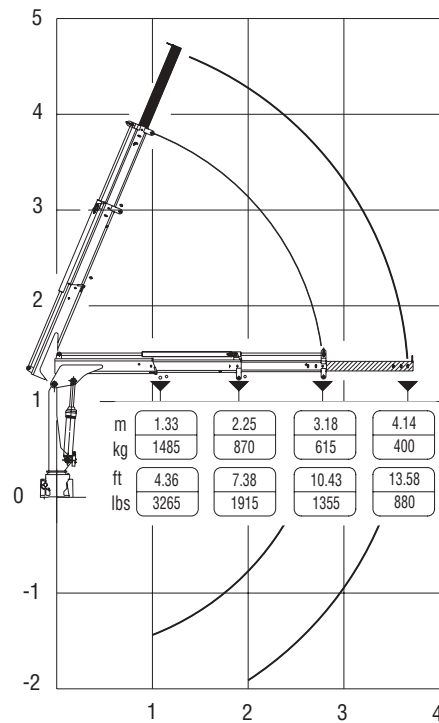

Questo dispositivo visualizza su un display collocato in prossimità dei comandi il carico applicato al gancio della gru, rendendo l'utilizzo delle prolunghe meccaniche sicuro secondo la normativa europea EN 12999.

This device shows the load at the hook on a display placed near the controls, making safe the use of the mechanical booms following the European rule EN 12999.

