



Where workmanship is everything

# TC-140 D-ICER PLUS ELECTRIC TAILGATE REPLACEMENT SPREADER for all one-ton dumps



## FEATURES:

- All electric - needs no hydraulic system
- 1/2 HP auger drive moves 10,000 lb/hr mat'l
- 1/6 HP LEESON Washdown™ spinner motor—epoxy coated, stnls shaft, in protected housing
- Universal mount kit fits any one-ton body
- Constructed of extruded T-6 alloy & aluminum sheet for durability & weight savings
- Installed unit weight - 275 lbs
- Backlit, fused, 100 AMP controller provides independently variable motor control
- Spinner remains level with pavement
- Horizontal spinner motor & right-angle drive provides maximum road clearance
- Stainless steel auger, spinner & hardware
- Installs in less than 6 hours
- Auger reducer is premium helical gear type for 98% efficiency
- Spreads any free-flowing mat'l's up to 3/4" dia.
- Waterproof Packard & Deutz motor connectors
- One year factory warranty

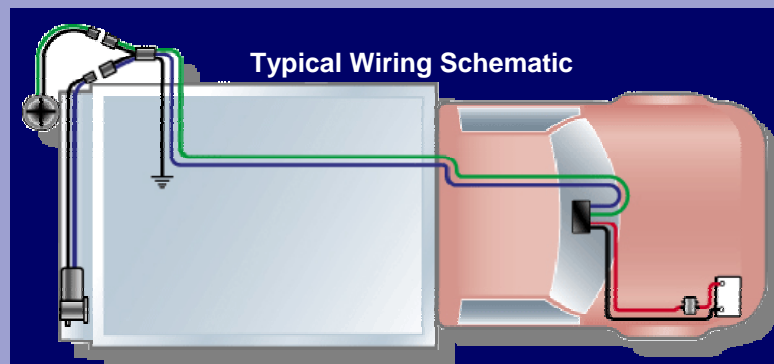
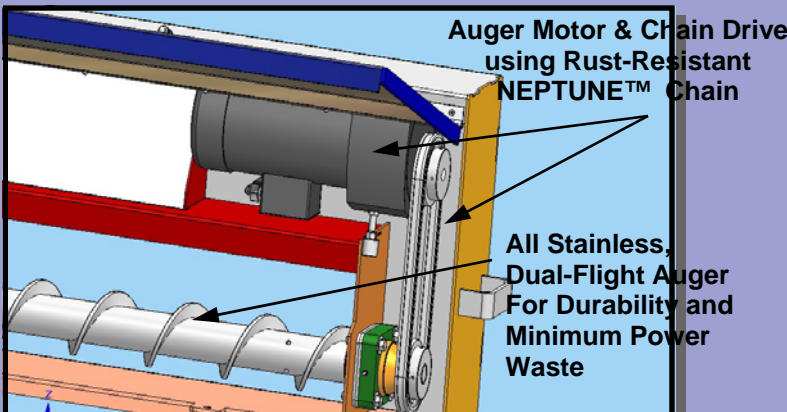
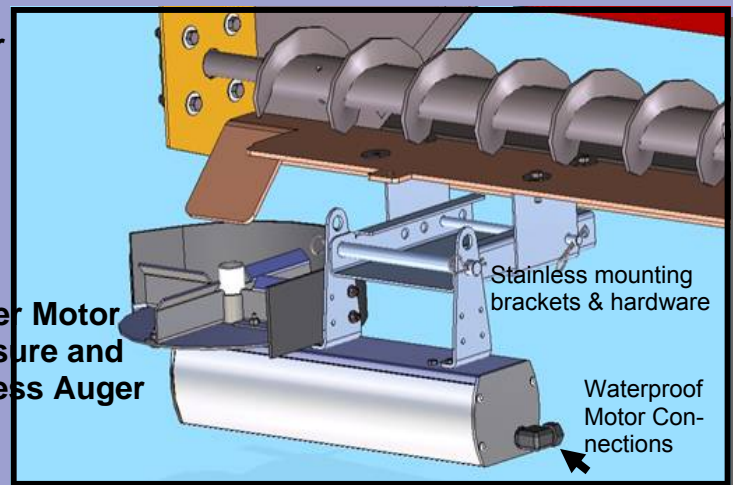

TRUCKCRAFT CORPORATION • 5751 MOLLY PITCHER HWY S. • CHAMBERSBURG, PENNSYLVANIA • 17202  
TOLL FREE 1-800-755-3867 • FAX 1-717-375-2975 • E-MAIL SALES@TRUCKCRAFT.COM • WWW.TRUCKCRAFT.COM