



STELLAR® I0628 TECHNICAL SPECIFICATION GUIDE

10628

Service Crane and T2-11 Service Body



Our People. Our Products.

STELLAR® I0628 TECHNICAL SPECIFICATION GUIDE

■ SPECIFICATION INFORMATION

| | |
|--|---|
| Crane Rating: | 55,000 ft-lbs (7.60 ton-m) |
| Standard Boom Length: | 12' 4" (3.76 m) from CL of Crane |
| Boom Extension: | |
| • 1st stage: | Hydraulic 96" (243.8 cm) |
| • 2nd stage: | Hydraulic 96" (243.8 cm) |
| Max. Horizontal Reach: | 28'4" (8.64 m) from CL of Crane |
| Max. Vertical Lift: (from crane base) | 29' 4" (8.64 m) |
| Boom Elevation: | -5° to +80° |
| Stowed Height: (crane only) | 34" (86.4 cm) |
| Mounting Space Required: | 20" x 21" (50.8 x 53.3 cm) |
| Shipping Weight: | 2900 lbs (1315 kg) |
| Controls: | Radio control standard for all functions. |
| Winch | |
| • Rope Diameter: | 7/16" (1.11 cm) |
| • Line pull speed: | 60 ft/min (18.29 m) |
| • Max. single part line: | 5000 lbs (2268 kg) |
| • Max. double part line: | 10,000 lbs (4535 kg) |
| Rotation: | 400° power (worm gear) |
| Lifting Capacities: | 4450 lbs @ 12'4" (2020 kg @ 3.76 m) 1925 lbs @ 28'4" (875 kg @ 8.64 m) |
| Power Supply Required: | PTO & Pump 8 gpm @ 3000 psi (30.3 lpm @ 207 bars) |

NOTE: All Stellar cranes meet ANSI B30.5 and OSHA 1910.180 specifications. Specifications subject to change without notification.

■ DEFINING CHARACTERISTICS

Remote Control

Stellar Industries was the first U.S. manufacturer to include the state-of-the-art fully proportional multi-functional remote control as a standard feature. The radio remote incorporates a variable speed trigger that allows the operators to feather the crane with precise control. Additionally, the radio remote control handle features engine start/stop functions, compressor on/off, engine speed controls, and an emergency shut-off.

Planetary Drive Winch System

To maximize winch speed, Stellar Industries has incorporated a planetary drive winch system with line speeds up to 60-ft/min (18.29 m), giving the 10628 crane over twice the speed of the competition. In addition to speed, the planetary winch also provides mechanical and hydraulic breaks for added security.

Hexagonal Boom Design

Hexagonal booms are stronger and greatly reduce boom flex and side to side movement.

Greaseless Bushings

Maintenance free greaseless bushings.

Stainless Steel Pivot Pins

Lower maintenance and extend life.

28' of Hydraulic Reach

2-stage hydraulic extensions. No manual extensions.

Dual Acting Counter Balance Valves

Integrated into cylinders.

Flip Sheave Standard

Anti Two-Block Device

10628 CAPACITY CHART

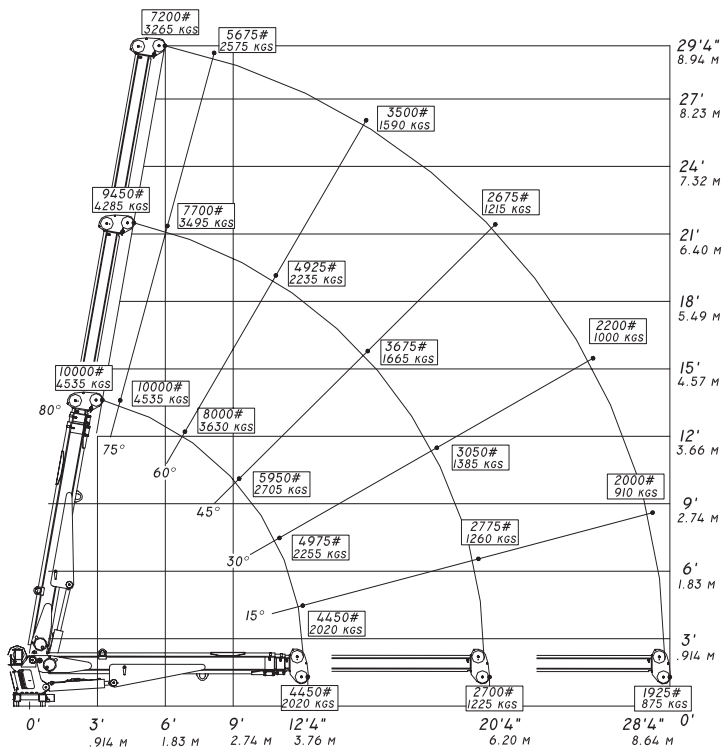

Weight of load handling devices are part of the load lifted and must be deducted from the capacity.

Maximum 1 - part line capacity is 5000 lbs. (2270 kg). For greater loads, use 2 - part line.

GEOMETRIC DIMENSIONS

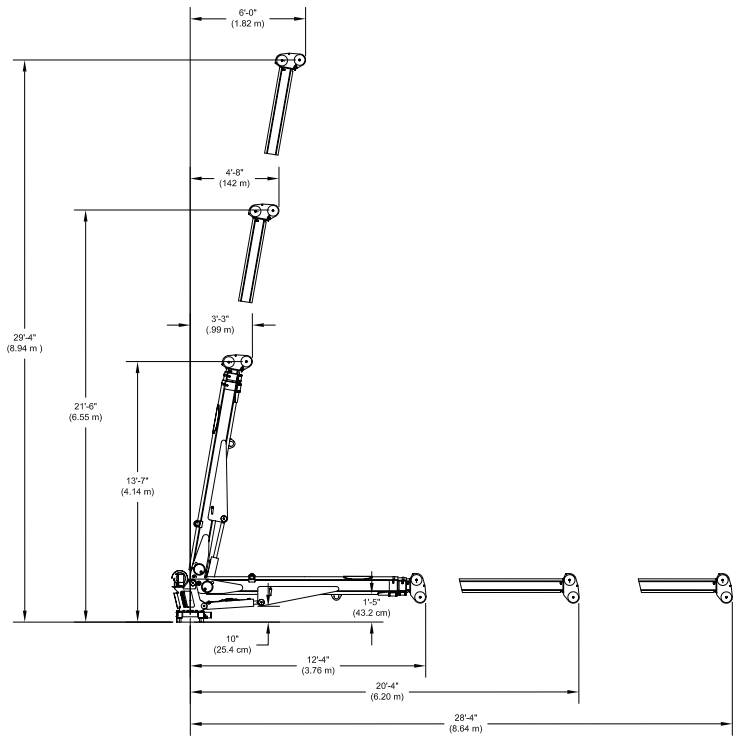

ROTATIONAL CLEARANCE

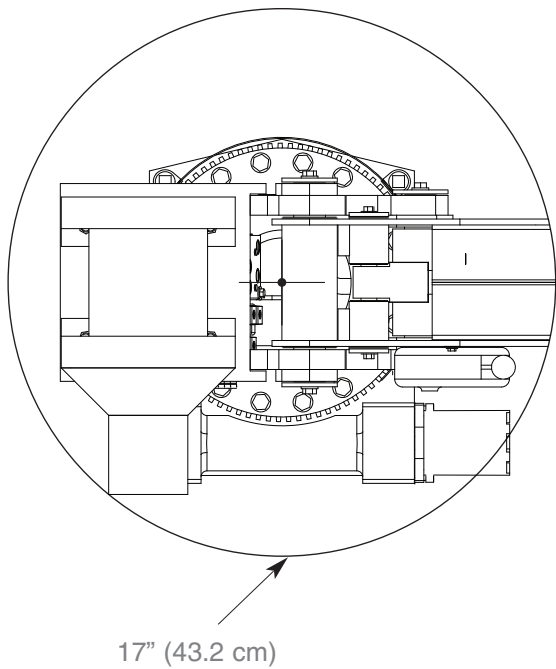

HOLE MOUNTING DETAIL

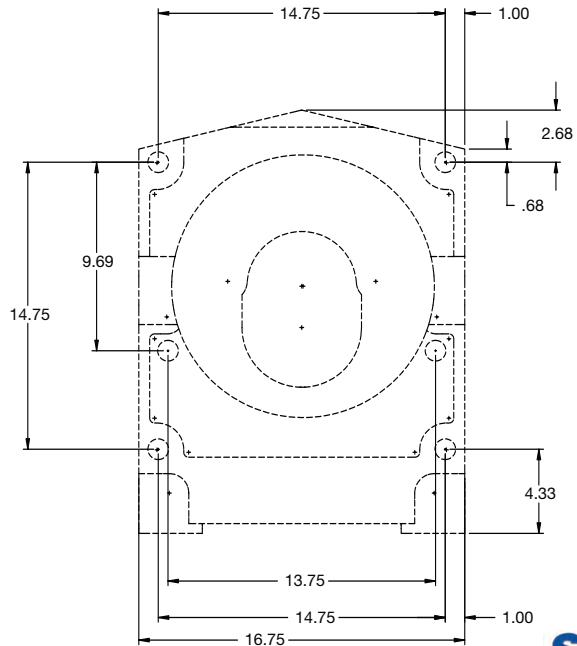

■ Service Bodies

T2-11 Service Body

Applicable Chassis: 19000 GVWR Chassis
and up

Crane Models: 6620
6628
9620
10620
10628

Cab to Axle: 84" (213.36 cm)
Body Length Nominal: 133" (337.82 cm)
Body Height: 52" (132.08 cm)
Body Width: 94" (238.76 cm)
Compartment Depth: 22" (55.88 cm)
Floor Width: 50" (127 cm)
Net Weight: 3600 lbs (1632.93 kg)

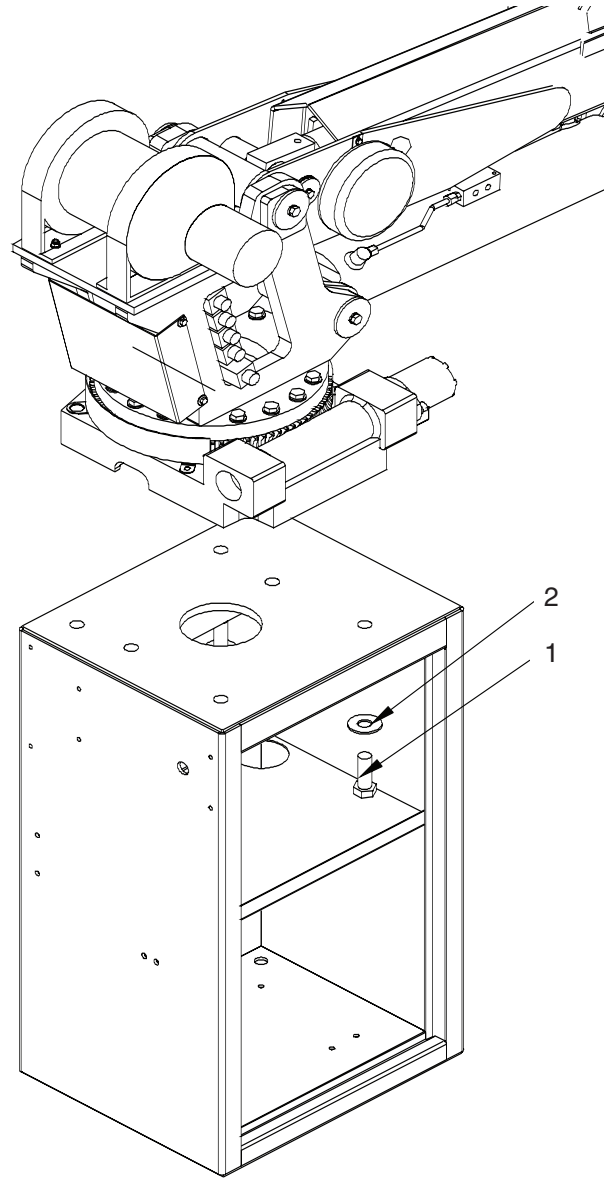
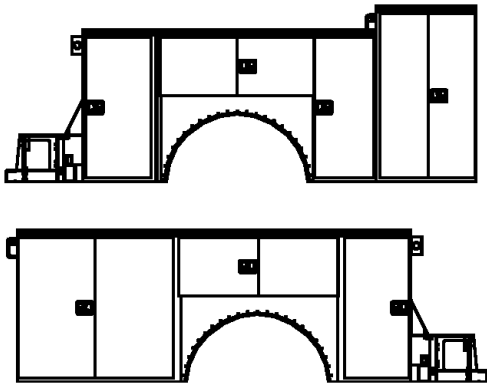

| Item | Part | Description | Qty. |
|------|------|------------------------------|------|
| 1 | 5199 | Cap Scr 1.00-8x3.00 HHGRB ZY | 6 |
| 2 | 1433 | Washer 1.00 USS Flat Zinc | 6 |

Your local dealer:



Our People. Our Products.

190 State Street
P.O. Box 169
Garner, IA 50438
Telephone: (641) 923-3741 • (800) 321-3741
Fax: (641) 923-2812
Internet: www.stellarindustries.com
Email: sales@stellarindustries.com

An Employee Owned Company.
Copyright © 2008 Stellar Industries, Inc.