



**STELLAR® I0620 TECHNICAL SPECIFICATION GUIDE**

# 10620

Service Crane and T2-11 Service Body



*Our People. Our Products.*

# STELLAR® I0620 TECHNICAL SPECIFICATION GUIDE

## ■ SPECIFICATION INFORMATION

Crane Rating:	55,000 ft-lbs (7.60 ton-m)
Standard Boom Length:	10' 9" (3.28 m) from CL of Crane
Boom Extension:	
• 1st stage:	Hydraulic 60" (152.4 cm)
• 2nd stage:	Hydraulic 60" (152.4 cm)
Max. Horizontal Reach:	20'9" (6.32 m) from CL of Crane
Max. Vertical Lift: (from crane base)	22' (6.71 m)
Boom Elevation:	-5° to +80°
Stowed Height: (crane only)	34" (86.4 cm)
Mounting Space Required:	20" x 21" (50.8 x 53.3 cm)
Shipping Weight:	2150 lbs (975 kg)
Controls:	Radio control standard for all functions.
Winch:	
• Rope Diameter:	7/16" (1.11 cm)
• Line pull speed:	60 ft/min (18.29 m)
• Max. single part line:	5000 lbs (2268 kg)
• Max. double part line:	10,000 lbs (4535 kg)
Rotation:	400° power (worm gear)
Lifting Capacities:	5100 lbs @ 10'9" (2315 kg @ 3.28 m) 2650 lbs @ 20'9" (1200 kg @ 6.32 m)
Power Supply Required:	PTO & Pump 8 gpm @ 3000 psi (30.3 lpm @ 207 bars)

NOTE: All Stellar cranes meet ANSI B30.5 and OSHA 1910.180 specifications.  
Specifications subject to change without notification.

## ■ DEFINING CHARACTERISTICS

### Remote Control

Stellar Industries was the first U.S. manufacturer to include the state-of-the-art fully proportional multi-functional remote control as a standard feature. The radio remote incorporates a variable speed trigger that allows the operators to feather the crane with precise control. Additionally, the radio remote control handle features engine start/stop functions, compressor on/off, engine speed controls, and an emergency shut-off.

### Planetary Drive Winch System

To maximize winch speed, Stellar Industries has incorporated a planetary drive winch system with line speeds up to 60-ft/min (18.29 m), giving the 10620 crane over twice the speed of the competition. In addition to speed, the planetary winch also provides mechanical and hydraulic breaks for added security.

### Hexagonal Boom Design

Hexagonal booms are stronger and greatly reduce boom flex and side to side movement.

### Greaseless Bushings

Maintenance free greaseless bushings.

### Stainless Steel Pivot Pins

Lower maintenance and extend life.

### 20' of Hydraulic Reach

2-stage hydraulic extensions. No manual extensions.

### Dual Acting Counter Balance Valves

Integrated into cylinders.

### Flip Sheave Standard

### Anti Two-Block Device

### 10620 CAPACITY CHART

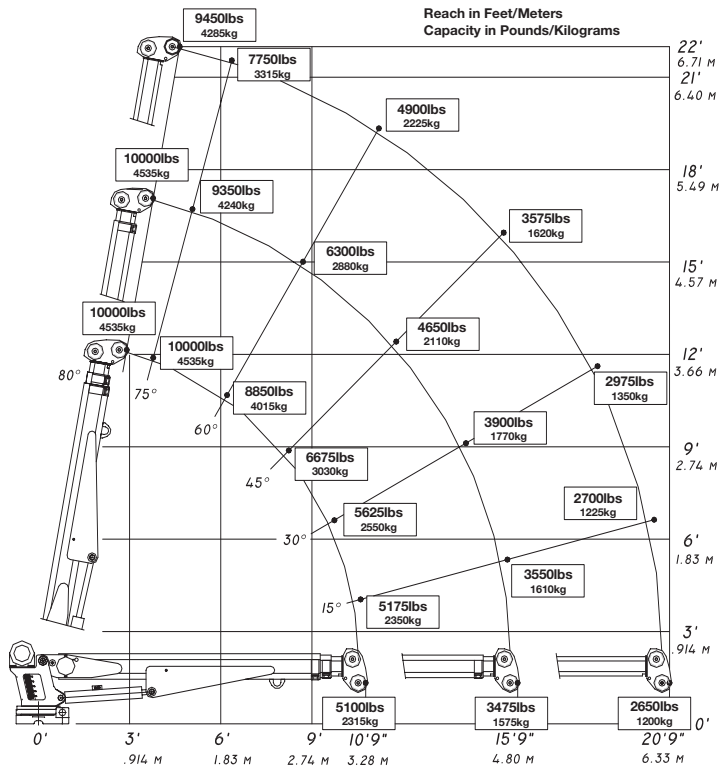

Weight of load handling devices are part of the load lifted and must be deducted from the capacity.

Maximum 1 - part line capacity is 5000 lbs. (2270 kg). For greater loads, use 2 - part line.

### GEOMETRIC DIMENSIONS

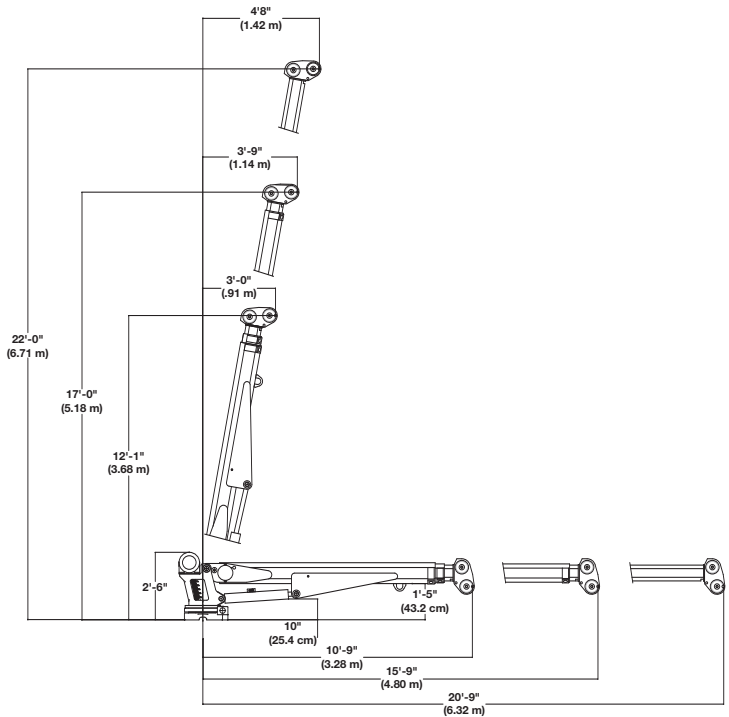

### ROTATIONAL CLEARANCE

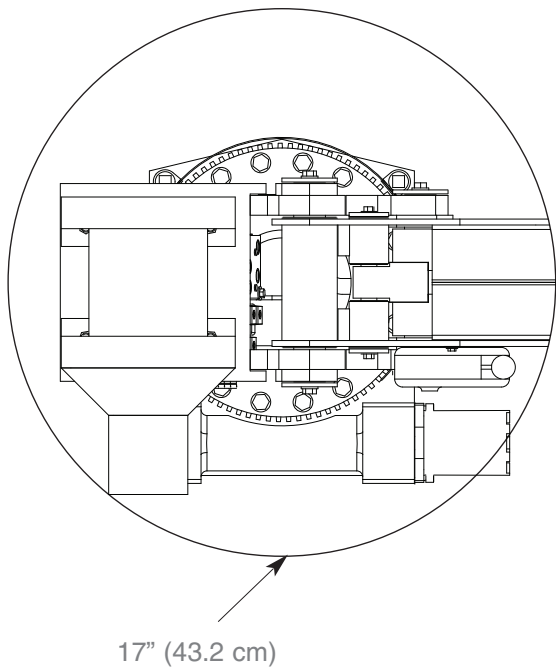

### HOLE MOUNTING DETAIL

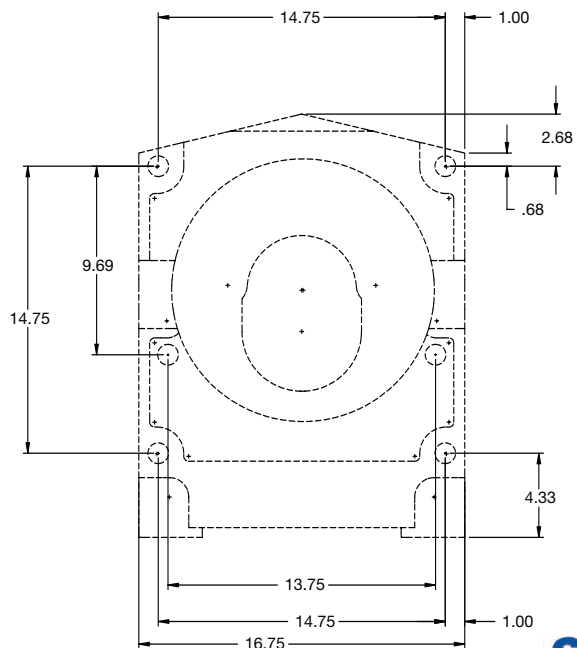

■ Service Bodies

**T2-11 Service Body**

Applicable Chassis: 19000 GVWR Chassis and up

Crane Models: 6620  
6628  
9620  
10620  
10628

Cab to Axle: 84" (213.36 cm)  
Body Length Nominal: 133" (337.82 cm)  
Body Height: 52" (132.08 cm)  
Body Width: 94" (238.76 cm)  
Compartment Depth: 22" (55.88 cm)  
Floor Width: 50" (127 cm)  
Net Weight: 3600 lbs (1632.93 kg)

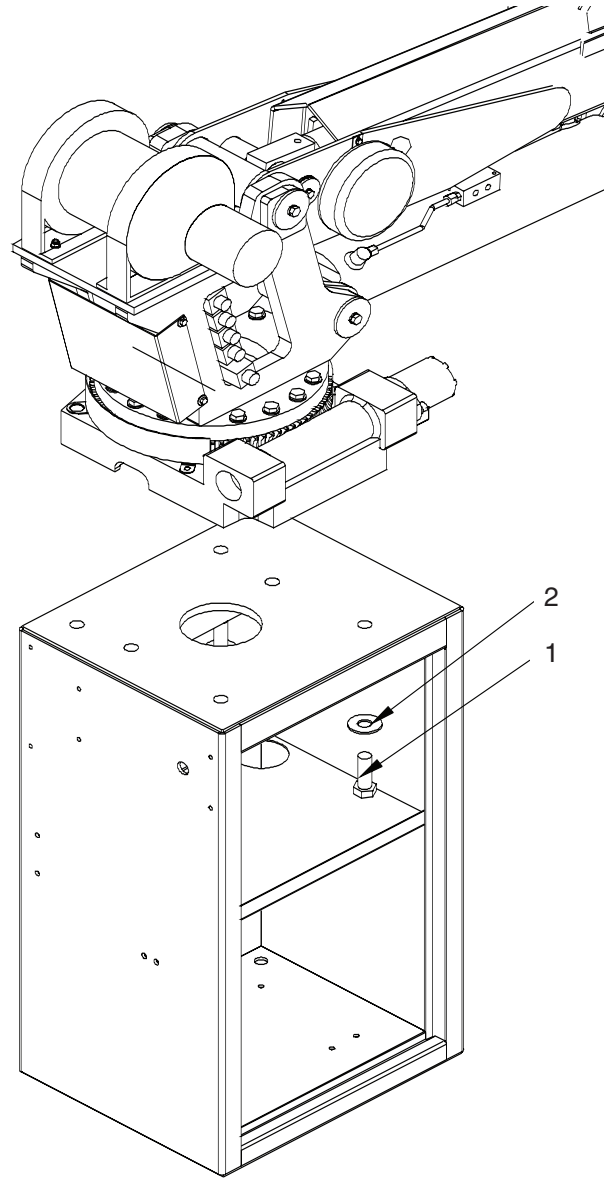
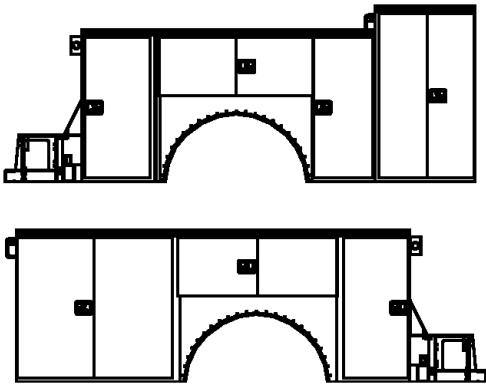

Item	Part	Description	Qty.
1	5199	Cap Scr 1.00-8x3.00 HHGRB ZY	6
2	1433	Washer 1.00 USS Flat Zinc	6

Your local dealer:



*Our People. Our Products.*

190 State Street  
P.O. Box 169  
Garner, IA 50438  
Telephone: (641) 923-3741 • (800) 321-3741  
Fax: (641) 923-2812  
Internet: [www.stellarindustries.com](http://www.stellarindustries.com)  
Email: [sales@stellarindustries.com](mailto:sales@stellarindustries.com)

An Employee Owned Company.  
Copyright © 2008 Stellar Industries, Inc.